

行星革新起重  
科技改变行业



## HANGING GOURP 新型悬挂电动葫芦

河南三智装备科技有限公司  
Henan Sanzhi Equipment Technology Co., Ltd

**SZW**

**CATALOGUE**  
目录

01\

**Company Profile**  
公司简介

02\

**Technical Parameter**  
技术参数

03\

**Product Advantages**  
产品优势

04\

**Service**  
服务



**SZW**

TECHNOLOGY CHANGES INDUSTRIES  
科技改变行业

# COMPANY PROFILE

## 企业简介



# SZW

CREATING QUALITY WITH CARE  
用心造品质

## COMPANY PROFILE 企业简介

河南三智装备科技有限公司,位于河南(长垣)起重工业园区,是一家专业设计、生产起重机配套零部件的企业。在传动领域享有很高的声誉,已与国内多家起重行业公司达成合作。三智以科技创新产品,以服务引领未来,以品质为根本、质量为基要。为用户提供卓越的产品、精准的服务。为起重机配套零部件,开拓更先进的供应链和市场模式。凭借雄厚的专业底蕴,独具匠心的研发能力,科学完备质量、服务、管理体系,向新老客户 provide 值得信赖的增值服务和产品。助力降低成本,精建优质产品。

公司的主要产品有:新型行星电动葫芦、新型行星电动双梁小车、新型低净空电动葫芦、五合一行星车轮组(车轮、行星减速机、联轴器、电机、制动器)、车轮组、行星减速机、行星变幅器等。结构部件的制作均严格按照欧洲工艺标准进行生产,整机性能超越国外同类产品的技术水平,技术满足于不同客户的需求,上下求索细研品质,让卓越品质成为给予客户的坚实保障。公司产品广泛应用于冶金、矿山、起重运输、电力、化工、造船、路港、电子、军工、食品等行业。

以匠心精雕细琢,用品质赢得信赖,  
我们不做市场的过客,只做行业的标杆。



用科技突破品质边界,以创新定义行业标准,  
我们不止于合格,更追求极致。

服务不是流程,而是一场双向奔赴,  
您的满意,是我们最大的成就。

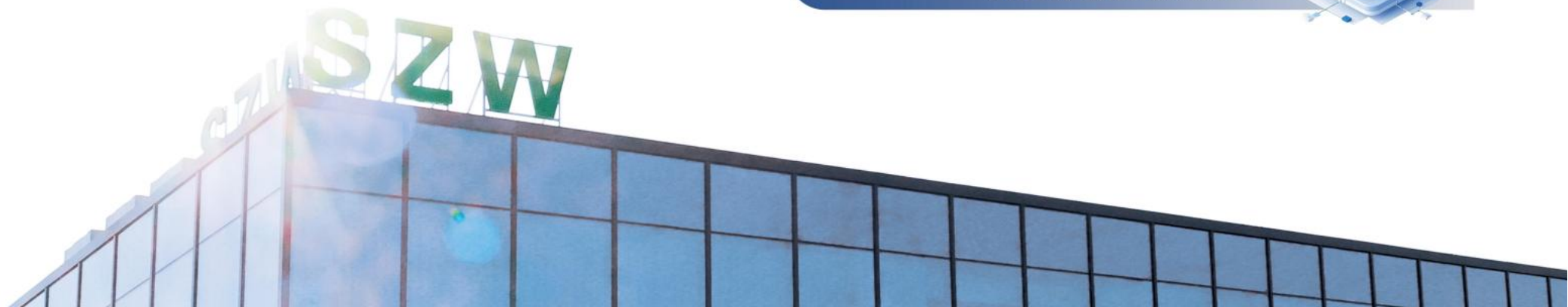

**SZW**



WIN THE FUTURE WITH INNOVATION  
用新赢未来



**技术参数**  
**TECHNICAL  
PARAMETER**

# SZW

PLANETARY INNOVATION CRANE  
行星革新起重

## PARAMETER 技术参数

### A ASx NEW SUSPENSION ELECTRIC HOIST ASx新型悬挂电动葫芦

由电机、行星减速器、卷筒、制动器、限位器等部分组成。4/2垂直下绳、内置行星减速机、双电机驱动且八个跑车轮运行结构平稳行,星齿轮传动结构使葫芦的整体布局更加合理,外形尺寸小,能够适应空间有限的工作环境。

It consists of components such as the motor, planetary gear reducer, drum, brake, and limit switch. With a 4/2 vertical rope lowering mechanism, built-in planetary gear reducer, dual motor drive, and eight running wheels, the structure operates smoothly. The planetary gear transmission design makes the overall layout of the hoist more rational, with compact dimensions, enabling it to adapt to space-constrained working environments.



ASx 新型悬挂电动葫芦		ASx new suspension electric hoist	
起重量	2t/3.2t/5t/10t/16t /18t/20t	Lifting capacity	2t/3.2t/5t/10t/16t/18t/20t
起升高度	6m/9m/12m/18m	Lifting heights	6m/9m/12m/18m
起升速度	5/0.8m/min (单、双速或变频调速)	Lifting speed	5/0.8m/min (single, double speed or variable frequency control)
工作级别	M4/M5	Classification group	M4/M5
运行速度	5~20m/min (变频调速)	Travelling speed	5-20m/min (variable frequency control)

SZW

TECHNOLOGY CHANGES INDUSTRIES  
科技改变行业

PARAMETER  
技术参数

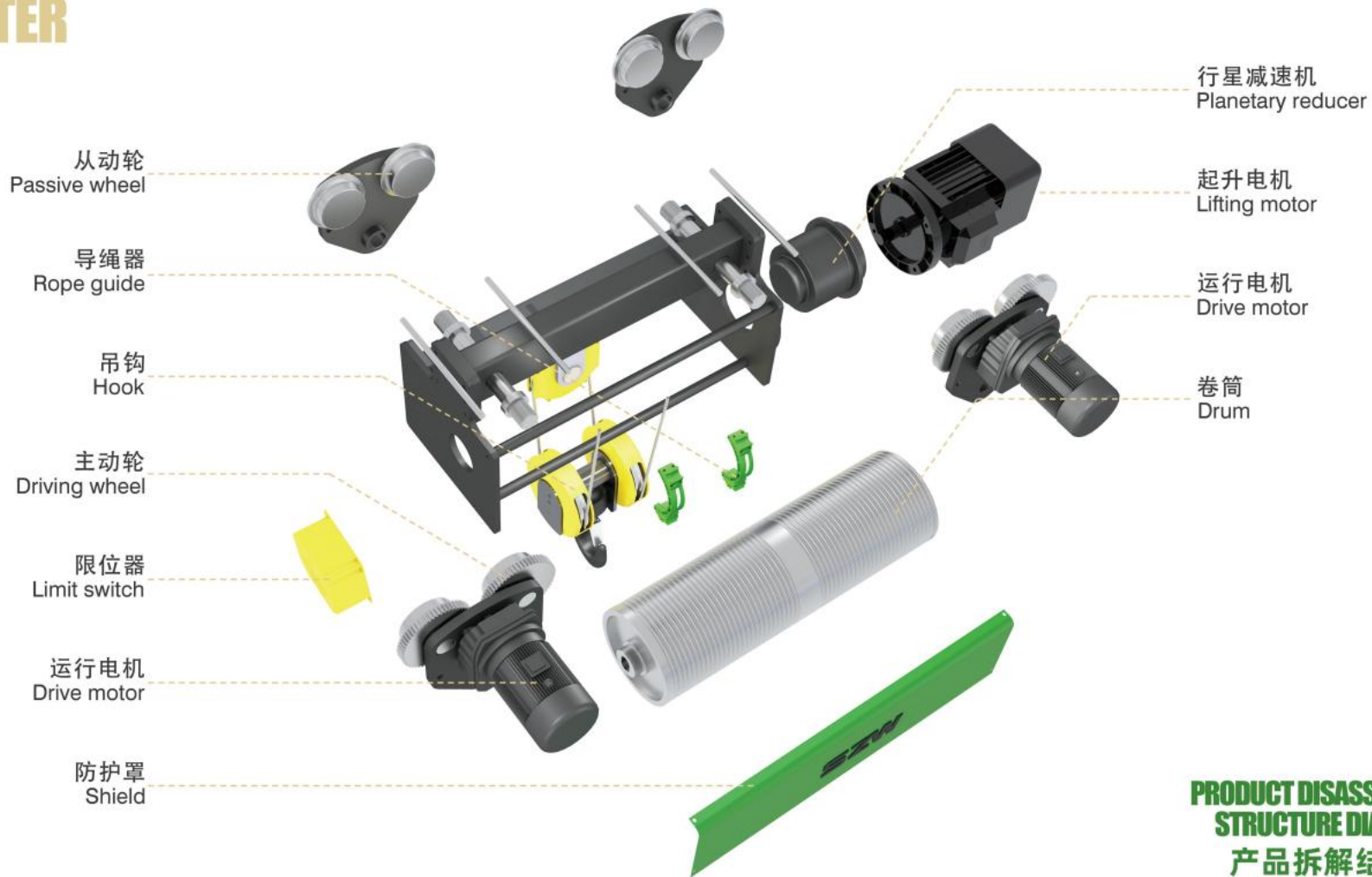

SZW

CREATING QUALITY WITH CARE  
用心造品质

**PRODUCT ADVANTAGES**  
**产品优势**

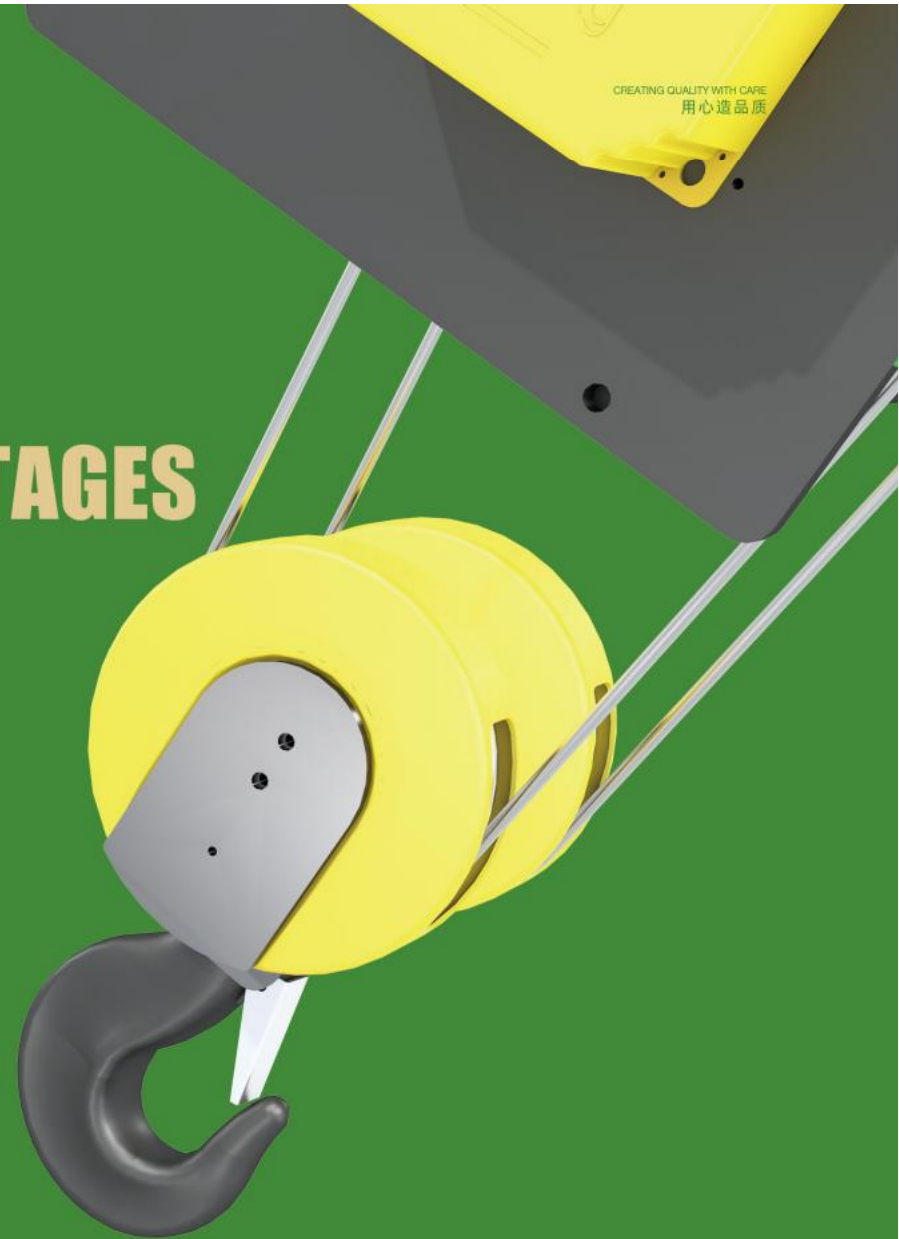

# SZW

WIN THE FUTURE WITH INNOVATION  
用新赢未来

## ADVANTAGES 产品优势

### 1 ROPE GUIDE 导绳器

使用粘塑性极强的高韧性合成材料制成，其具有耐磨性好，使用周期长，即使在恶劣情况下也有极高的安全性。自动调节松紧，自动压紧钢丝绳，避免吊钩落地松绳。

Made of highly adhesive and ductile synthetic materials, it has good wear resistance, long service life, and extremely high safety even in harsh conditions. Automatically adjust the tension and tighten the steel wire rope to prevent the hook from falling and loosening the rope.

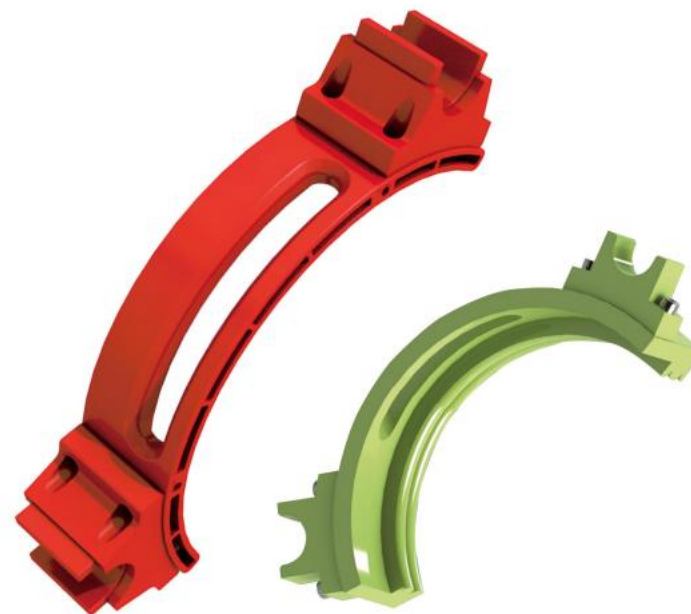

导绳器	Rope guide
排绳精准	Accurate rope arrangement
安全性能高	High security performance
减少磨损	Reduce wear and tear
安装维护便捷	Easy installation and maintenance
增强稳定性	Enhance stability
助力效果好	Good assistance effect

## ADVANTAGES

### 产品优势

## 2 PLANETARY REDUCER

### 行星减速机

由太阳轮、行星轮、行星架、内齿圈四大基本构建组成。广泛兼容性与适应性、卓越的性能、强大的扭矩传递能力、安全可靠的设计、体积小，自重轻，扭矩大、耐冲击、免维护设计、市场认可与广泛应用、成本优势。行星减速机加工工艺按照汽车16949工艺标准执行，所有齿轮均是20CrMoTi渗碳淬火，同比传统平行轴减速机，抗冲击性、耐用性均大幅提高，目前已广泛应用于工程机械、通过起重机械、港口机械等领域。

It consists of four basic components: sun gear, planetary gear, planetary carrier, and internal gear ring. Wide compatibility and adaptability, excellent performance, powerful torque transmission capability, safe and reliable design, small size, light weight, high torque, impact resistance, maintenance free design, market recognition and wide application, cost advantage. The processing technology of planetary reducers follows the 16949 process standard for automobiles, and all gears are 20CrMoTi carburized and quenched. Compared with traditional parallel axis reducers, the impact resistance and durability have been greatly improved. Currently, it has been widely used in engineering machinery, lifting machinery, port machinery and other fields.



#### 行星减速机

#### Planetary reducer

传动效率高

High transmission efficiency

传动比精确

Accurate transmission ratio

结构紧凑

Compact

承载能力强

Strong carrying capacity

运转平稳、噪声低

Smooth operation and low noise

免维护

Maintenance-free

# SZW

TECHNOLOGY CHANGES INDUSTRIES  
科技改变行业

## ADVANTAGES 产品优势

### 3 MOTOR 电机

高端起重装备特制电机，制动盘合金铝压铸加工成型后经调质处理，避免了由于刹车锅过疲劳崩碎，引起的不可估量的事故。特殊结构设计，避免了双速电机点动出现温度升高，停顿等异常情况。

The high-end lifting equipment is equipped with a specially designed motor, and the brake disc is made of aluminum alloy die-casting and processed through quenching and tempering treatment, which avoids incalculable accidents caused by excessive fatigue and breakage of the brake pan. Special structural design avoids abnormal situations such as temperature rise and pause caused by the double speed motor jogging.



电机	Motor
结构紧凑	Compact
高效节能	Efficient and energy-saving
运行稳定	Stable operation
散热良好	Good heat dissipation
控制精度高	High control accuracy
强度刚度高	High strength and stiffness

# SZW

CREATING QUALITY WITH CARE  
用心造品质

## ADVANTAGES 产品优势

### 4 NEW TYPE OF HOOK 新型吊钩

100吨以下滑轮组采用偏心设计，减少从卷筒到吊钩滑轮组的夹角，提高钢丝绳使用寿命，吊钩组采用T级吊钩，按钩号材质为35CrMo或者34Cr2Ni2Mo；吊钩螺母和吊钩横梁采用材质35CrMo；吊钩钩壳采用高分子材料冲压而成，经久耐用。

The pulley system with a capacity of less than 100 tons adopts an eccentric design to reduce the angle from the drum to the hook pulley system, improve the service life of the steel wire rope, and the hook system adopts a T-grade hook, which is made of 35CrMo or 34Cr2Ni2Mo according to the hook number material; The hook nut and hook crossbeam are made of 35CrMo material; The hook shell is made of polymer material stamped and durable.



新型吊钩	New type of hook
安全性高	High safety
使用寿命长	long service life
防脱钩设计	Anti decoupling design
耐用材质	Durable material
维护成本低	Low maintenance cost
设计人性化	Humanized design

# SZW

## ADVANTAGES 产品优势

### 5 DRUM 卷筒

采用高强度钢材制造，经过严格的质量检测和热处理工艺，具有较高的强度、硬度和韧性，能够承受较大的起升载荷。

Made of high-strength steel and subjected to strict quality testing and heat treatment processes, it has high strength, hardness, and toughness, and can withstand large lifting loads.



WIN THE FUTURE WITH INNOVATION  
用新赢未来



卷筒	Drum
承载能力强	Strong carrying capacity
使用寿命长	long service life
制造精度高	High manufacturing precision
稳定性高	High stability
维护方便	Maintainable
高硬度高韧性	High hardness and toughness

# SZW

PLANETARY INNOVATION CRANE  
行星革新起重

## ADVANTAGES 产品优势

### 6 MULTIFUNCTIONAL LIMITER 多功能限位器

旋转限位、超速开关、激光测距、纠偏、上下层防撞；内置行星减速器设置，无限寿命设计；多功能限位集行程限位、高度限位、激光测距、纠偏、上下层防撞为一体，解决了行业痛点。

Rotation limit, overspeed switch, laser ranging, correction, upper and lower collision avoidance; Built in planetary gearbox setting, with an infinite lifespan design; The multifunctional limit integrates travel limit, height limit, laser ranging, correction, and upper and lower collision avoidance, solving industry pain points.

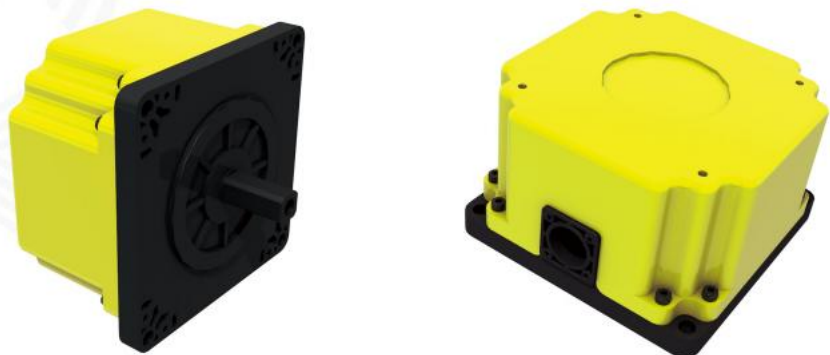

多功能限位器	Multifunctional limiter
精确限位控制	Precise limit control
安全性能卓越	Excellent safety performance
设计安装便捷	Easy to design and install
维护保养轻松	Easy maintenance and upkeep
材质坚固耐用	Durable and sturdy material
用户体验良好	Good user experience

# SZW

TECHNOLOGY CHANGES INDUSTRIES  
科技改变行业

## ADVANTAGES 产品优势

### 7 INTEGRATED ELECTRICAL 集成电气

集成多种保护电路，制动控制等功能，具有完美性能及低价成本；标准化程度高，体积紧凑，安装方便，里面控制线路已固化，用户只要简单接入电源进线以及电机线，信号线就能正常运行。

Integrate multiple protection circuits, brake control and other functions, with perfect performance and low cost; Highly standardized, compact in size, easy to install, and the control circuit inside has been solidified. Users only need to simply connect the power input line and motor line, and the signal line can operate normally.



#### 集成电气

#### Integrated Electrical

高度集成化

Highly integrated

高可靠性

High reliability

降低能耗

Reduce energy consumption

智能化控制

Intelligent control

易于扩展和升级

Easy to expand and upgrade

故障诊断与预警

Fault diagnosis and warning

# SZW

CREATING QUALITY WITH CARE  
用心造品质

## ADVANTAGES 产品优势



### ◆ Structure Design 结构设计

体积小重量轻：整体结构紧凑，占用空间小，重量较轻，既可以单独悬挂在轨道上吊运物体，也方便与多种起重机进行配套安装使用，对起重机的整体负荷影响小。模块化设计：采用模块化设计，通用性和组合性强，便于安装、维护和更换部件，可根据不同的使用需求进行灵活组合，降低了维护成本和设备的停机时间，提高了设备的使用效率。

### ◆ Performance Performance 性能表现

运行平稳：运行过程中十分平稳，可保证起重机在起吊货物时，货物的晃动极小。耐冲击：采用优质的材料及力学工程设计，抗载能力更强，可在高负荷状态下稳定运行，能够承受较大的重量负荷和频繁的冲击。可频繁启动：可以频繁地进行启动和停止操作。超静音：采用超静音设计，运行时产生的噪音非常低，能降低工作环境中的噪音污染。

### ◆ Application adaptation 应用适配

适配性强：是一种轻小型起重设备，既可以单独悬挂在轨道上吊运物体，也可与电动单梁、电动悬挂、悬臂起重机、桥式、门式等多种起重机配套使用，能适配各种起重机，应用场景广泛，可应用于货场、仓库、商店、工厂、矿山等多种吊装场景。

SZW



WIN THE FUTURE WITH INNOVATION  
用新赢未来



服务  
SERVICE

### ◆ BEFORE SERVICE

#### 售前服务

免费为用户提供技术咨询服务；向用户提供产品样本，企业简介，资信证明等资料；诚邀至我司考察产品设计、工艺流程和质量管理体系；委派技术人员根据现场情况和用户需求进行设计、选型。

### ◆ IN SALES SERVICE

#### 售中服务

产品制造过程中，用户相关人员可到我公司监察制造过程中各个工序；向用户相关人员提供产品全流程制造检验标准和制造检验结果。

### ◆ AFTER-SALE SERVICE

#### 售后服务

结合用户需求进行培训，及时改进产品；坚决执行产品“三包”服务政策；对客户来电来函信息8小时内处理完毕答复，服务工程师24小时待命制，离开现场需客户许可；批量订单业务，提供为期三个月保姆式跟踪服务。





河南三智装备科技有限公司  
Henan Sanzhi Equipment Technology Co., Ltd

公司网址 <http://www.szwzb.com>  
服务热线 0373-8698966  
公司地址 河南省长垣市起重工业园区纬二路1号

Website <http://www.szwzb.com>  
Tel 0373-8698966  
Address No.1 Weier Road Industrial Park Changyuan City Henan Province